

### EXAMPLE CONNECTIONS

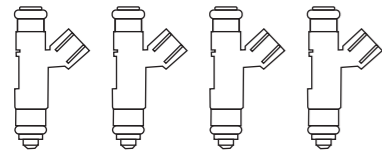

INJECTORS

**INJECTORS**  
 4 X INJECTOR DRIVERS  
 CURRENT CONTROLLED  
 • 0A - 8A PEAK CURRENT  
 • 0A - 2A HOLD CURRENT  
 ALL SPARE INJECTOR OUTPUTS CAN BE USED AS GENERIC DPO'S WITH 1A MAX OUTPUT  
 OUTPUT: GROUND

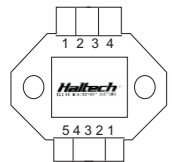
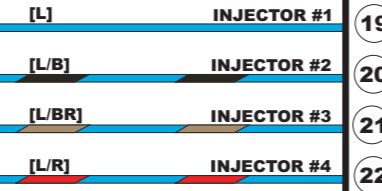

IGNITION MODULE

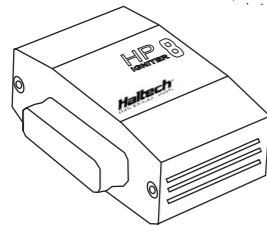

HALTECH HPI

**IGNITION**  
 4 X IGNITION DRIVERS  
 • 1A MAX CURRENT  
 • OVERCURRENT PROTECTED  
 ALL SPARE IGNITION OUTPUTS CAN BE USED AS GENERIC DPO'S WITH 1A MAX OUTPUT  
 OUTPUT: GROUND

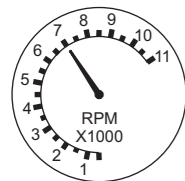
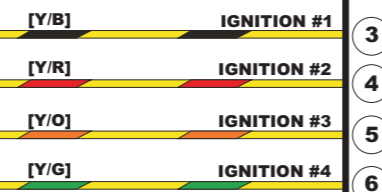

TACHOMETER

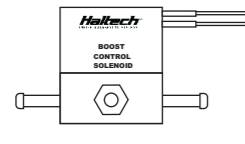

BOOST CONTROL SOLENOID

**DPO**  
 6 X DIGITAL PULSED OUTPUTS  
 • LOW SIDE DRIVE  
 • 1A MAX CURRENT  
 • OVERCURRENT PROTECTED  
 OUTPUT: GROUND

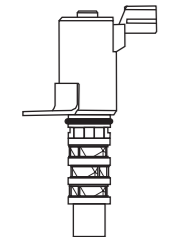
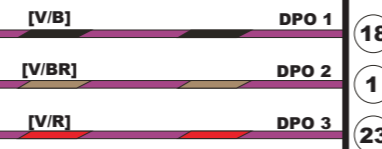

VTEC SOLENOIDS

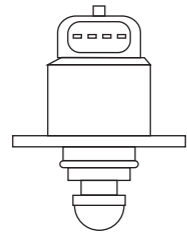

IDLE MOTOR

**STEPPER 1 / DPO**  
 CAN BE CONFIGURED AS  
 • 1 X STEPPER MOTOR DRIVER PAIRED P1 & P2 / P3 & P4  
 • 4 X HI/LOW SIDE DRIVERS  
 SPECIFICATIONS  
 • 1A MAX CURRENT DRIVE  
 • 1A MAX CURRENT SINK  
 • OVERCURRENT PROTECTED  
 OUTPUT: BATT V OR GROUND

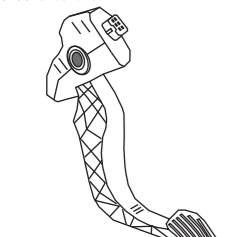
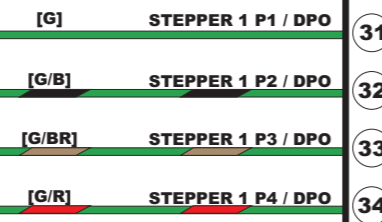

ACCELERATOR PEDAL POSITION SENSOR

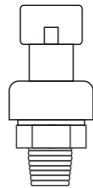

PRESSURE SENSORS

**AVI**  
 10 X ANALOGUE VOLTAGE INPUTS  
 • SWITCHABLE 1K PULL-UP  
 • 20V MAX INPUT VOLTAGE  
 • 1.5KHz MAX INPUT FREQUENCY  
 INPUT: 0V - 5V (20V MAXIMUM)



**+5V SENSOR SUPPLY**  
 • 100mA MAX OUTPUT CURRENT



**+8V SENSOR SUPPLY**  
 • 1A MAX OUTPUT CURRENT



### LOOKING INTO CONNECTOR ON ECU

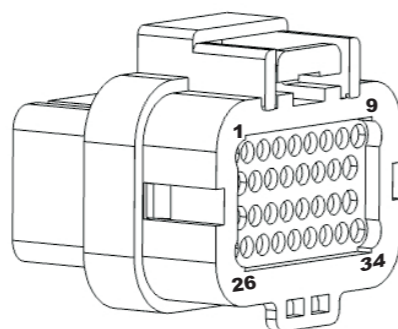
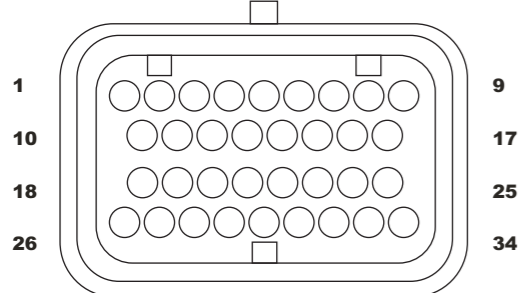

### LEGEND - WIRE COLOUR

B = BLACK BR = BROWN G = GREEN GY = GREY L = BLUE  
 O = ORANGE P = PINK R = RED V = VIOLET Y = YELLOW W = WHITE  
 WHEN TWO COLOURS ARE USED IN A WIRE BY THE ALPHABETICAL CODE, THE FIRST LETTER INDICATES THE BASIC WIRE COLOUR, THE SECOND COLOUR INDICATES THE COLOUR OF THE STRIPE.

### NOTES:

- \*1 RECOMMENDED FUNCTION ALLOCATION, BUT NOT LIMITED TO
- \*2 CAN USE 75A CIRCUIT BREAKER

Haltech ELITE 1500 (2.5M) PREMIUM HARNESS #HT-140904	
HALTECH ENGINE MANAGEMENT SYSTEMS	
DOCUMENT REVISION: 3	HARNESS REVISION: 3
DATE: 1ST SEPTEMBER 2015	SHEET 1 OF 2

## 34 PIN CONNECTOR (A)

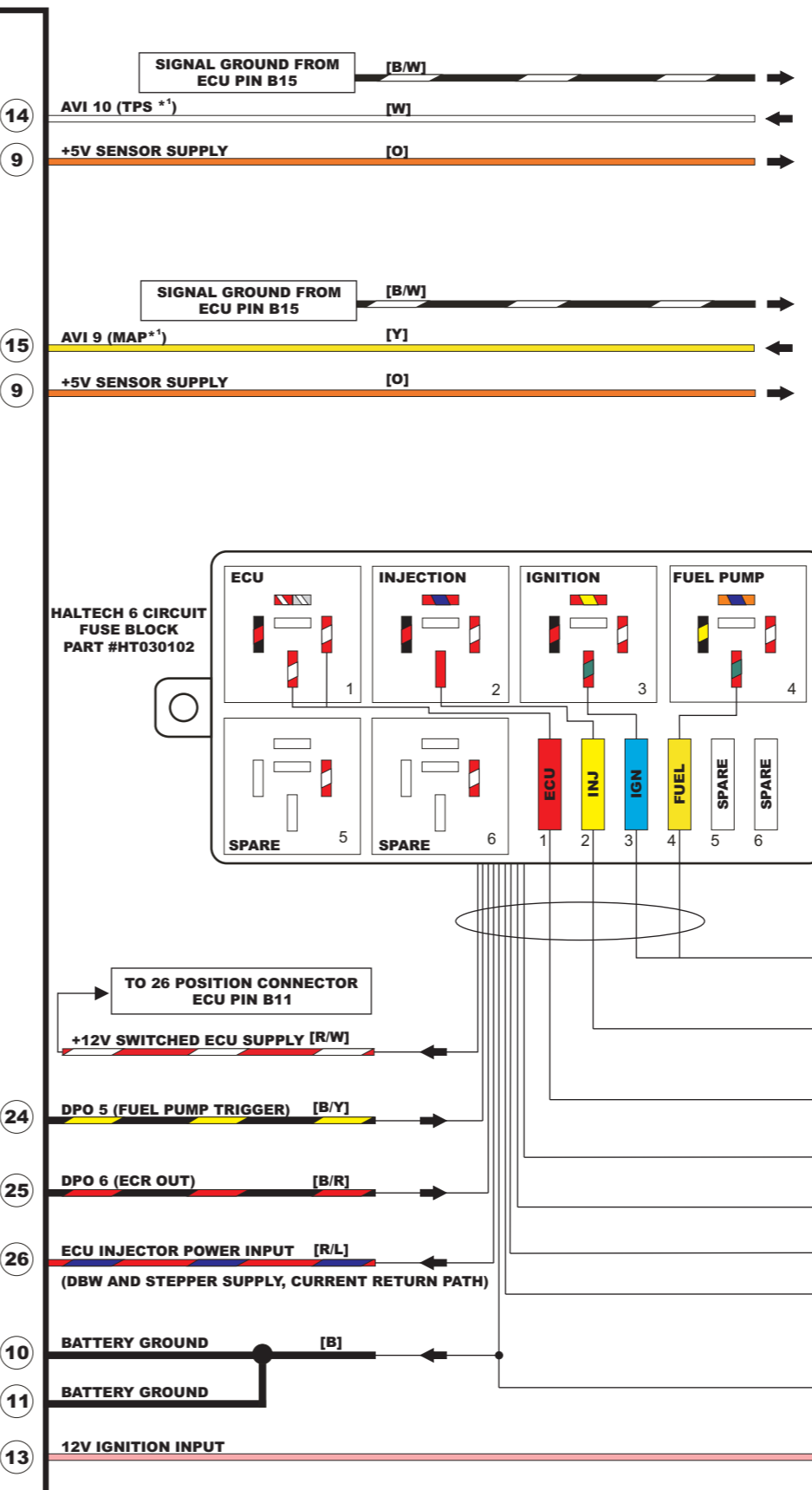

### EXAMPLE CONNECTIONS

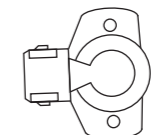

THROTTLE POSITION SENSORS

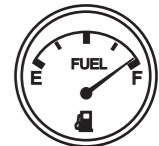

FUEL LEVEL SENSOR

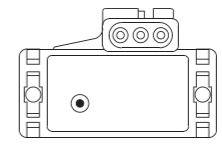

MANIFOLD ABSOLUTE PRESSURE SENSOR

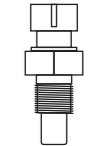

TEMPERATURE SENSORS

### FUSE BLOCK NOTES:

15A CONTINUOUS, 20A PEAK  
 MAX CURRENT RATING PER CIRCUIT  
**FUSE ALLOCATIONS**  
 FUSE 1: 10A - ECU  
 FUSE 2: 20A - INJECTION  
 FUSE 3: 15A - IGNITION  
 FUSE 4: 20A - FUEL PUMP  
 FUSE 5: SPARE  
 FUSE 6: SPARE

### RELAY PIN LAYOUT & SCHEMATIC

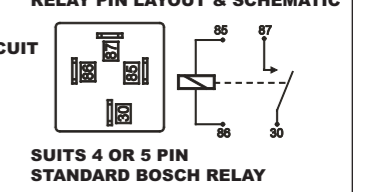

### EXAMPLE CONNECTIONS

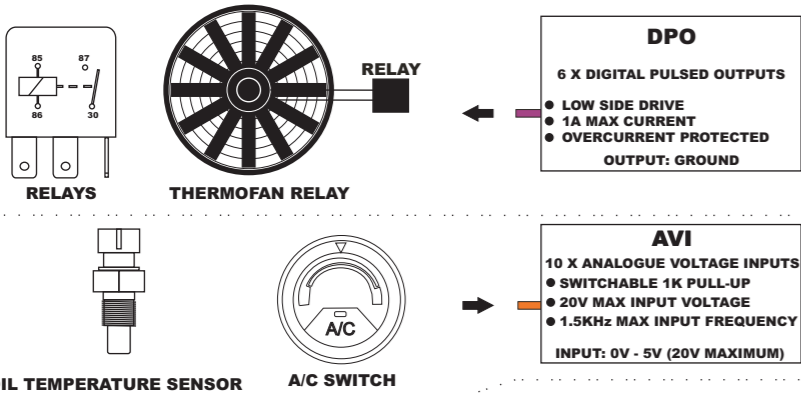

### EXAMPLE CONNECTIONS

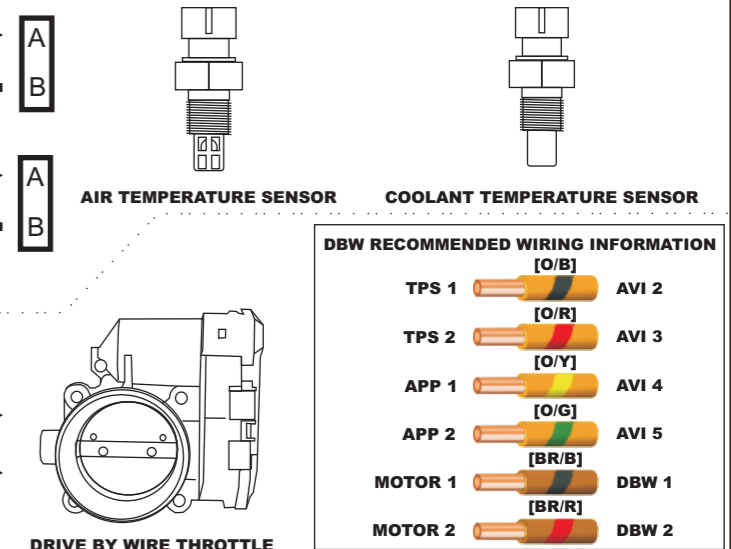

DBW RECOMMENDED WIRING INFORMATION [O/B]		
TPS 1	[O/B]	AVI 2
TPS 2	[O/R]	AVI 3
APP 1	[O/Y]	AVI 4
APP 2	[O/G]	AVI 5
MOTOR 1	[BR/B]	DBW 1
MOTOR 2	[BR/R]	DBW 2

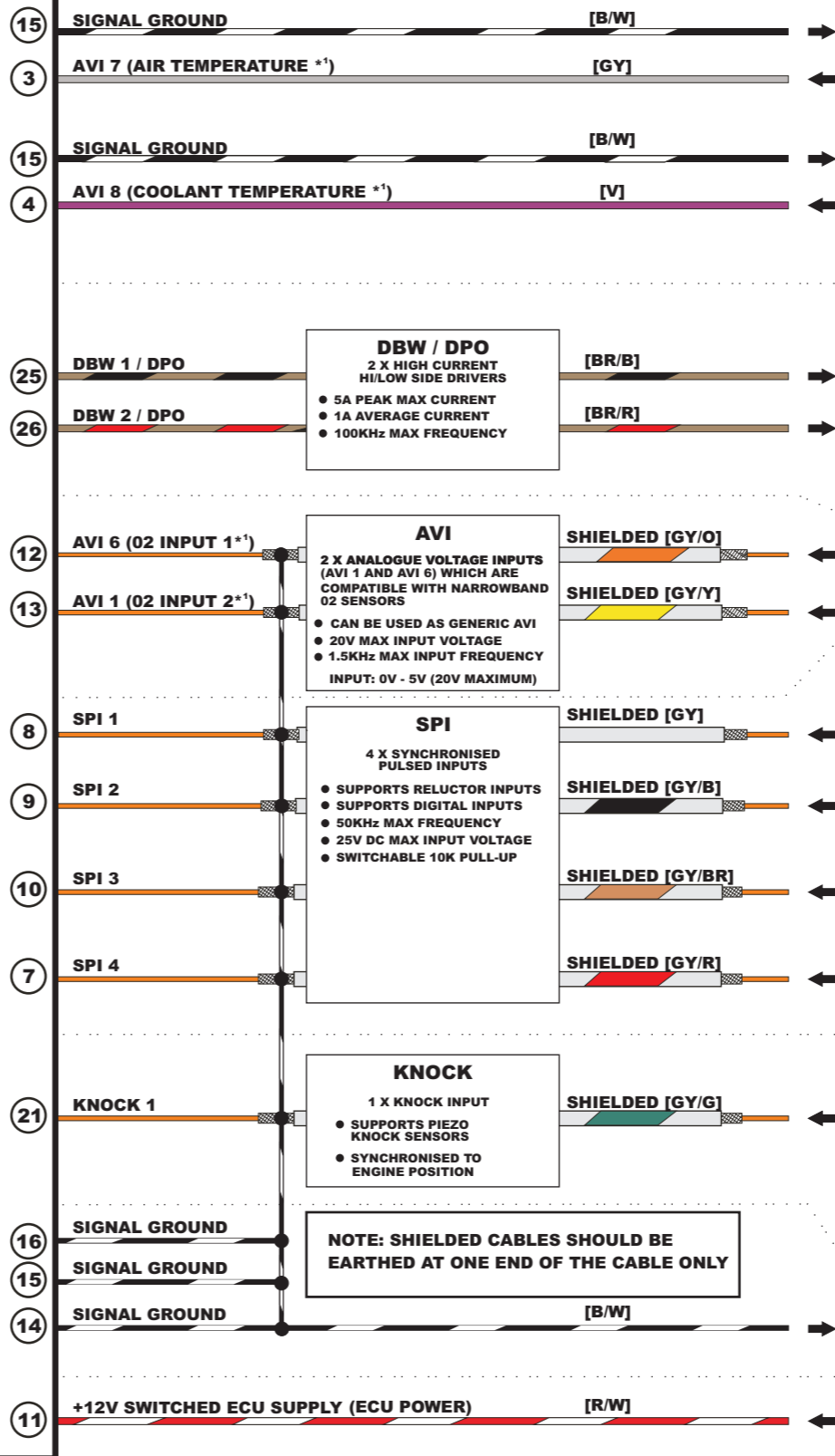
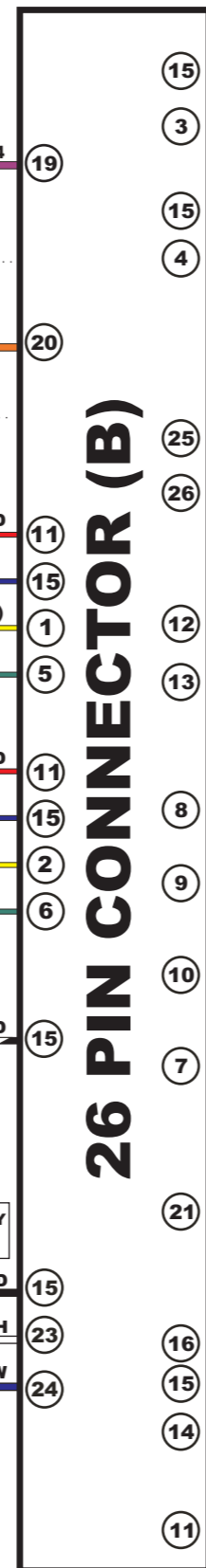

### CRANK (TRIGGER) INPUT

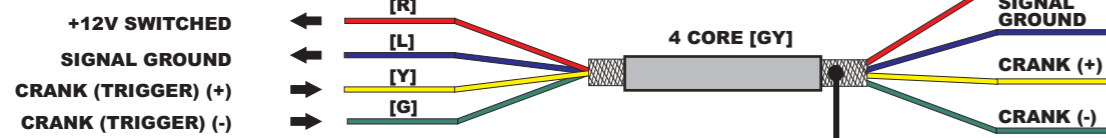

### CAM (HOME) INPUT

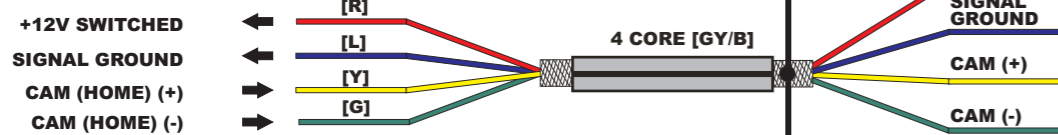

### CRANK AND CAM SENSOR WIRING INFORMATION

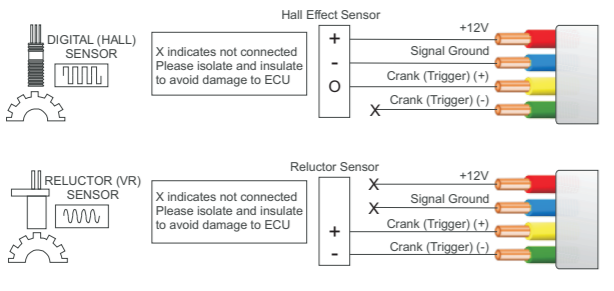

### MAIN HARNESS CAN CONNECTOR (DTM04-4P)

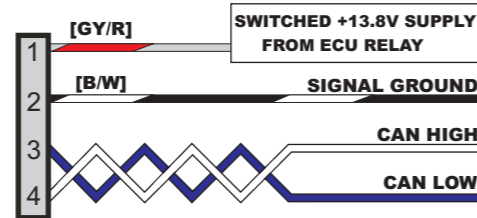

### CAN (ISO 11898)

- SUPPORTS SPEEDS UP TO 1Mbits/s
- HALTECH BUS**
  - SUPPORTS ALL HALTECH EXPANSION PRODUCTS
- VEHICLE BUS**
  - SELECTABLE PRECONFIGURED VEHICLE CAN INTERFACE
  - OBDDII COMPLIANT

### LOOKING INTO CONNECTOR ON ECU

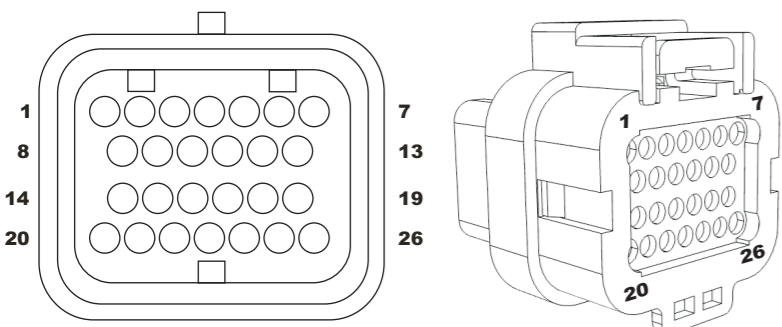

### LEGEND - WIRE COLOUR

B = BLACK BR = BROWN G = GREEN GY = GREY L = BLUE  
O = ORANGE P = PINK R = RED V = VIOLET Y = YELLOW W = WHITE  
WHEN TWO COLOURS ARE USED IN A WIRE BY THE ALPHABETICAL CODE, THE FIRST LETTER INDICATES THE BASIC WIRE COLOUR, THE SECOND COLOUR INDICATES THE COLOUR OF THE STRIPE.

### NOTES:

- \*1 RECOMMENDED FUNCTION ALLOCATION, BUT NOT LIMITED TO
- \*2 CAN USE 75A CIRCUIT BREAKER